

Name KEY

Student ID # _____

**BIO SCI 97 FALL 2004
FINAL EXAMINATION**

**DO NOT OPEN EXAM UNTIL TOLD TO DO SO
BEFORE BEGINNING:**

1. Write your **name** and **ID** number in the upper right corner of **this page**
2. Write your **name** and **ID** number on your **Scantron** card, and fill out the code box for your ID
3. Write your exam version number (see top of this page) on the Scantron right after your name
4. **SIGN THE BACK** of your Scantron card in the large white space
5. Write your **name** and **ID** number and exam version number on the answer sheet for Part II

DURING THE EXAM:

1. Choose the **SINGLE** best answer to each question. If none of the answers seem correct, or if more than one seems correct, choose the one that seems **most correct**.
2. For Part I, Mark your Scantron card with a dark **PENCIL**.
3. For Part II, answers that are not clearly and carefully written will be marked wrong.

VERY IMPORTANT:

1. You must sit in your assigned seat unless given permission to do otherwise. If you are not sitting in your assigned seat you may be given a zero on the exam.
2. This is a closed book test - no notes of any type are allowed.
3. Do not talk to another student. Do not look at another student's answers.
4. On desk - ID, Scantron, exam, answer sheet, pencil, calculator (calculator is optional).
5. If you are seen with a cell phone or pager you may be given a zero on the exam.

NOTES for all questions:

- Affected = has the disease
- Unaffected = does not have the disease (but may be a carrier if the disease is recessive)
- Normal = does not have the disease and is not a carrier.
- For all questions, assume any trait or disease mentioned has 100% penetrance, unless it is stated otherwise
- For inheritance questions, assume no new mutations, unless it is stated otherwise.
- All diseases mentioned are genetic diseases, unless it is stated otherwise.
- Pedigrees will only show you if someone is affected (black symbol) or unaffected (white symbol). If someone is a heterozygous carrier of a recessive disease, they will be depicted as unaffected.

PART 1 – MULTIPLE CHOICE – ANSWER ON YOUR SCANTRON CARD

Each question is worth one point. 22 points total.

1. Which of the following statements are true:
 - A. In x-linked dominant inheritance, it is possible for an unaffected woman to have an affected son
 - B. In x-linked dominant inheritance, it is possible for an affected man to have an unaffected daughter
 - C. In x-linked recessive inheritance, it is possible for an affected woman to have an unaffected son
 - D. In x-linked recessive inheritance, it is possible for an unaffected man to have an affected daughter
 - E. None of the above are true**

2. Which of the following statements is FALSE?:
 - A. It is more likely that a new mutation will create a gain-of-function allele than a loss-of-function allele**
 - B. Loss-of-function alleles are more likely to be recessive than dominant
 - C. A new mutation is more likely to inactivate a protein's function than to create a new function for that protein
 - D. It is quite unlikely that a new mutation will exactly reverse the sequence change caused by a prior mutation
 - E. All of the above are false

3. Klinefelter syndrome is most commonly associated with the karyotype 47, XXY, but it can also be caused by the karyotype 48, XXXY. How can the karyotype 48, XXXY occur?
 - A. Meiosis I or II non-disjunction in the mother and Meiosis II non-disjunction in the father
 - B. Successive non-disjunctive meiotic divisions in the father (that is, non-disjunction in meiosis I followed by non-disjunction(s) in meiosis II)
 - C. Successive non-disjunctive meiotic divisions in the mother
 - D. Meiosis I or II non-disjunction in the mother and Meiosis I non-disjunction in the father**
 - E. None of the above

4. A male with hypophosphatemic rickets marries a normal woman. They have 8 children (4 boys and 4 girls). All the boys are normal but all the females are affected. What type of inheritance does this suggest (that is, which is the most likely given the observations)?
 - A. Autosomal recessive
 - B. X-linked recessive
 - C. Autosomal dominant
 - D. X-linked dominant**
 - E. Y-linked dominant

5. A female carrier of hemophilia mates with a man afflicted with Huntington's disease. What percentage of their sons will have both hemophilia and Huntington's disease?
 - A. 100%
 - B. 75%
 - C. 50%
 - D. 25%**
 - E. 0%

6. What is the current estimate for the number of genes in the human genome?
 - A. 250
 - B. 2,500
 - C. 25,000**
 - D. 250,000
 - E. 2,500,000

The pedigree shows the inheritance of a genetic disease in three generations of a family

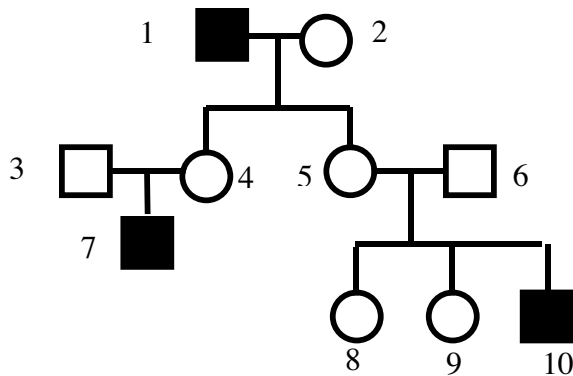

7. Based on the pedigree, the mode of inheritance of this disease could be
- Autosomal recessive
 - X-linked recessive
 - Autosomal dominant
 - X-linked dominant
 - A or B**
8. Assume that #7 was an affected female, instead of an affected male as shown. Given that assumption, then the mode of inheritance of this disease is most likely...
- Autosomal recessive**
 - X-linked recessive
 - Autosomal dominant
 - X-linked dominant
 - Y-linked dominant
9. There are hematopoietic stem cells that can make more of themselves, or differentiate into red or white blood cells. Also, there are cells that make sperm throughout a man's life. These are two examples of...
- differentiated cells
 - embryonic cells
 - germline cells
 - stem cells**
 - tumorigenic cells
10. The first widely successful genetically modified crop was a strain of soybeans that...
- That was trisomic for a soybean chromosome
 - Contained a gene that made them easier to round up using modern harvesting techniques
 - Contained a gene from another plant that made them grow faster
 - Contained a gene from a bacterium that made them resistant to a powerful herbicide**
 - None of the above
11. The name given to the discredited pseudoscientific movement that proposes that the human race could be improved by selective breeding is ...
- Natural Selection
 - Eugenics**
 - Heritability
 - Population Genetics
 - Genetic Engineering

The pedigree shows the inheritance of a genetic disease in three generations of a family

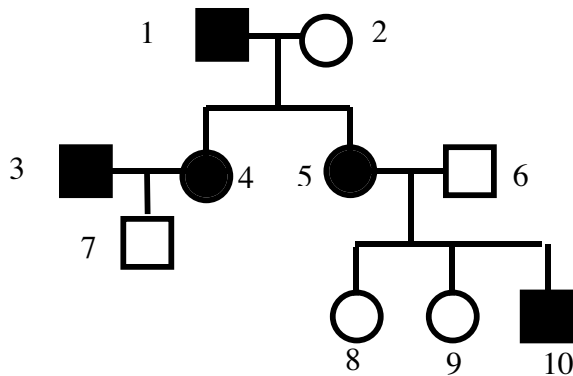

12. Based on the pedigree, the mode of inheritance of this disease could be
- Autosomal recessive
 - X-linked recessive
 - Autosomal dominant
 - X-linked dominant
 - C or D**
13. Assume that many more generations of this family are followed, and it is observed that affected men never have affected sons, whereas, on average, about half of the sons born to affected women are also affected. Given that assumption, then the mode of inheritance of this disease is most likely...
- Autosomal recessive
 - X-linked recessive
 - Autosomal dominant
 - X-linked dominant**
 - Y-linked dominant
14. A certain population is at Hardy-Weinberg equilibrium. In this population, there is an autosomal recessive condition. Without knowing the allele frequencies, what can you conclude about the genotype frequencies?
- The frequency of those affected by the condition is less than or equal to the frequency of carriers
 - The frequency of those affected by the condition is greater than the frequency of carriers
 - The frequency of heterozygotes is greater than the frequency of homozygotes
 - The frequency of those homozygous for the dominant allele is less than the frequency of those homozygous for the recessive allele
 - You can't conclude any of the above without knowing allele frequencies**
15. Which **one** of the following statements regarding reproductive cloning is the most correct?:
- Many human clones have lived to adulthood.
 - Only a few human clones have lived to adulthood.
 - Some attempts at human cloning have been made, but these individuals have died as embryos or shortly after birth.
 - There have been a few claims of successful human cloning, but none of them has been scientifically verified.**
 - No vertebrate animal has ever been cloned.

16. About how many new alleles are created by fixed mutations every time a gamete is formed?
- less than 1 new mutation per 100 gametes
 - about 1 per gamete**
 - dozens per gamete
 - hundreds per gamete
 - thousands per gamete
17. Which of the following statements about chromosomal rearrangements is NOT true:
- Chromosomal rearrangements cannot be passed from generation to generation to generation**
 - Conceptions with a gross chromosomal rearrangement usually abort spontaneously
 - Balanced chromosomal rearrangements typically do not cause severe symptoms in carriers
 - Duplications and deletions can result from unequal crossing over
 - A minimum of 10-15% of conceptions have a chromosomal abnormality
18. A man smokes two packs of cigarettes per day from age 11, quits smoking at age 37, has his first child at age 39 and is diagnosed with malignant lung cancer at age 40. "I begged you not to smoke," says his wife, "and now you've probably given our baby your cancer". Her statement is:
- reasonable, because cancer is a genetic disease
 - reasonable, due to the inheritance of acquired characteristics
 - reasonable, because the man probably had an inherited predisposition to cancer
 - not reasonable, because the carcinogenic mutations arose somatically and were not passed to the gametes**
 - not reasonable, because the man stopped smoking before he got cancer, hence there is no connection between the smoking and the cancer
19. Gleevec is a new drug used in the treatment of chronic myelogenous leukemia (CML). Gleevec binds to the Abl protein and inhibits its activity. Gleevec also shows promise in the treatment of gastrointestinal stromal tumors (GSTs), but has no effect on lung cancer.
- GSTs must be a type of CML that has been misclassified
 - Lung cancers have the "Philadelphia" chromosomal translocation
 - Abl activation is probably one of the genetic changes that results in GSTs**
 - Lung cancers and GSTs probably have mutations in the same oncogenes.
 - Lung cancers and GSTs must have no genetic changes in common.
20. An anxious man and an anxious woman mate and have a relatively calm kid. This is most consistent with which one of the following statements?:
- anxiety is a multifactorial trait with a heritability less than 1.0**
 - anxiety is a multifactorial trait with a heritability very close to 1.0
 - anxiety is subject to heterozygote superiority
 - anxiety is a single gene, recessive trait
 - anxiety is determined by the environment, not by genes
21. All of the following statements are FALSE except:
- Monozygotic twins arise from a single egg fertilized by two sperm
 - The variance of a trait is determined either by environmental or genetic variance, and never by both together
 - Athletic parents usually have athletic kids, hence the variation in athletic ability must be solely determined by genes
 - Complex traits can be categorized as either sex-linked or autosomal.
 - Simple genetic mechanisms involving a small number of genes can lead to a quantitative trait having an approximately normal distribution**

22. A woman claims that either basketball stars Shaq O'Neil or Coby Bryant is the father of her child. DNA samples are taken from her (M), her kid (K), Shaq (S) and Coby (C), and typed for a polymorphic locus on chromosome 3. The figure shows the banding pattern obtained by the Southern blot procedure.

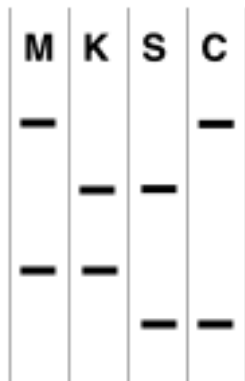

- A. Shaq may be the father, but Coby cannot be
 B. Shaq cannot be the father, but Coby may be
 C. Shaq cannot be the father, and Coby cannot be the father either
 D. Either man could be the father
 E. The kid is a clone of Shaq

PART II - Short Answer Questions – Not Scantron – Write on Part II Answer Sheet

23 points total. Questions are worth 2 points each unless otherwise indicated

23-24. The translation initiation (“start”) codon is ATG (in DNA). The three translation termination (“Stop”) codons are TAA, TAG and TGA. Below are shown nucleotide sequence of the first four codons in the open reading frame of the wild-type allele for a particular gene, as well as the sequences of three mutant alleles.

Wild-type allele: ATG GGG TAC CGC AGC...
 Mutant #1: ATG GGG GTA CCG CAG...
 Mutant #2: ATG AGG TAC CGC AGC...
 Mutant #3: ATG GGG TAG CGC AGC...

23. For each mutant allele, indicate whether it is
 A. Missense
 B. Nonsense
 C. Frameshift
 D. Silent

#1 C, #2 A, #3 B; 2/3 pt each, round down

24. Which of the three mutant alleles is likely to cause the least dramatic effect on the function of the encoded protein?

#2

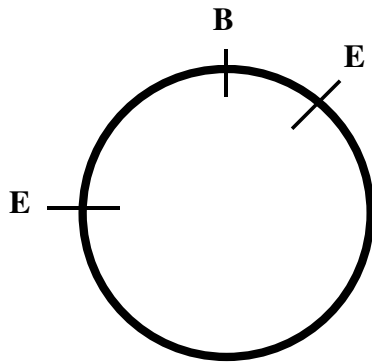

25. The figure to the left shows an 8 kb plasmid molecule containing a single cleavage site for the BamHI (B) restriction endonuclease, and two EcoRI (E) cleavage sites. The first EcoRI sites is 2kb from the BamHI site; the second EcoRI site is 1kb from the BamHI site

25a. If the plasmid is cleaved with BamHI only, what size fragment(s) will there be? **8 kb**

25b. If the plasmid is cleaved with EcoRI only, what size fragment(s) will there be? **5 kb, 3 kb**

26. Which of the following genetically modified (GM) organisms exist? (you may choose none, or more than one):

- A. **Bacterial that carry a human gene and express the corresponding human protein.**
- B. **Tobacco plants that glow because they carry a gene from fireflies.**
- C. Humans pituitary dwarfs that carry the gene for human growth hormone in their germline.
- D. **Mice that grow to larger than normal size because they carry the gene for human growth hormone.**
- E. Talking parrots that carry the genes for human speech.

+1 point each for A,B,D / -2 points each for C or E / Min 0 Max 2

27. A certain population is at Hardy-Weinberg equilibrium. In this population, there is an autosomal recessive disease, and the frequency of those affected by the disease is exactly equal to the frequency of heterozygous carriers for that disease. What is q , the frequency of the disease-causing allele, in this population?

$q = 2/3$

28-31. In a certain population of genetics students at Hardy-Weinberg equilibrium, the gene for attention span has two alleles, **A** and **a**, which act in a codominant manner. Individuals of the AA genotype (blabbermouths) talk too much during lectures, whereas individuals of the aa genotype (sleepyheads) fall asleep during lectures; heterozygotes are well-behaved. At the beginning of the term, in a class of 1000 students, there are 90 sleepyheads.

28a. What is the frequency of the **A** allele at the beginning of the term? **0.7**

28b. What is the frequency of the **a** allele at the beginning of the term? **0.3**

29. During the course of the term, the professor kicks out all 90 sleepyheads. He also kicks out 210 blabbermouths, so that by the end of term the population has are only 700 students left.

29a. What is the frequency of the **A** allele in the population at the end of the term? **0.7**

29b. What is the frequency of the **a** allele in the population at the end of the term? **0.3**

29c. Is the population at Hardy-Weinberg equilibrium at the end of the term? **No**

(1 point for both a & b correct; 1 point for c correct)

30. (1 point) The type of selection applied by the professor most closely resembles (choose one)...

- A. **Heterozygote superiority**
- B. Inbreeding
- C. Poor selection against rare deleterious recessive alleles in diploids
- D. Random mating
- E. Mutation
- F. A and B
- G. All of the above (A-E)
- H. None of the above (A-G)

31. At the end of the term, the professor locks the students in the classroom with plenty of food and water and leaves them there for 200 years, during which time they undergo 10 rounds of random mating with no selection, mutation or genetic drift.

31a. What is the frequency of the **A** allele in the population at the end of the 200 years? **0.7**

31b. What is the frequency of the **a** allele at the end of the 200 years? **0.3**

31c. Is the population at Hardy-Weinberg equilibrium at the end of the 200 years? **Yes**

31d. At the end of the 200 years, the professor's granddaughter examines the genotype of the 1000 people drawn at random from the population. How many sleepyheads should she find, on average (your answer should be a number between 0 and 1000)? **90**

(1/2 point for both a & b; 1 point for c; 1/2 point for d, round down)

32. (3 points) When Dolly the sheep was cloned by nuclear transfer.....

32a. was the transferred nucleus haploid or diploid? **diploid**

32b. was it taken from a somatic cell or a germline cell? **somatic**

32c. what type of cell was it put into, **egg or embryo or embryonic or embryonic stem cell** and what key manipulation had been done to that cell? **It was enucleated (its nucleus was removed)**

33. (3 points) Three crosses were performed involving the linked genes Arr, But and Dmb. The Ang gene has alleles A & a, the But gene has alleles B & b, and the Dmb gene has alleles D & d. The genotypes obtained, and the frequency at which they were obtained, is given below: :

AB/ab x ab/ab : 41% AB, 39% ab, 9% Ab, 11% aB

AD/ad x ad/ad : 37% AD, 33% ad, 16% Ad, 14% aD

BD/bd x bd/bd : 43% BD, 42% bd, 7% Bd, 6% bD

33a. What's the distance between Arr and But? (give the distance and include the appropriate unit of distance in your answer; answer "unlinked" if you think Arr and But are not linked).

20 cM or centimorgans or map units (no points if units not given)

33b. What's the distance between But and Dum? (give the distance and include the appropriate unit of distance in your answer; answer "unlinked" if you think But and Dum are not linked).

13 cM or centimorgans or map units (no points if units not given)

33c. Which gene is in the middle?

But (no points for "B" or "b")

HAPPY HOLIDAYS!