

Name _____

Student ID # _____

UCI Access (extension) students check here:

BIO SCI 97, GENETICS, FALL 2006 FINAL EXAMINATION

DO NOT OPEN EXAM UNTIL TOLD TO DO SO

BEFORE BEGINNING:

1. Write your **name** and **ID** number in the upper right corner of **this page** (and check the box if you're an extension student)
2. Write your **name** and **ID** number on your **Scantron** card, and bubble in the code box for your ID. Also, if you're an extension student, put an "X" in front of your written ID number, e.g X0698337
3. Write your exam version number (see top of this page) on the Scantron right after your name
4. Write your **name** and **ID** number on the answer sheet for Part II
5. Read the section below marked "very important" and sign the pledge.
6. Bubble in your section and exam versions on the scantron as directed by the Professor

VERY IMPORTANT:

1. You must sit in your assigned seat unless given permission to do otherwise.
If you are not sitting in your assigned seat you may be given a zero on the exam.
2. This is a closed book test - no notes of any type are allowed.
3. Do not talk to another student. Do not look at another student's answers.
4. On desk - ID, Scantron, exam, answer sheet, pencil, calculator (calculator is optional). No notes, formulas, etc may be stored in calculator.
5. If you are seen with a cell phone or pager you may be given a zero on the exam.

Pledge: I have read this page. I understand the rules and I pledge that I will not cheat on this exam or help others to do so.

_____ (sign your name here)

NOTES for all questions:

- Affected = has the disease
- Unaffected = does not have the disease (but may be a carrier if the disease is recessive)
- Normal = does not have the disease and is not a carrier.
- For all questions, assume any trait or disease mentioned has 100% penetrance, unless it is stated otherwise
- For inheritance questions, assume no new mutations, unless it is stated otherwise.
- All diseases mentioned are genetic diseases, unless it is stated otherwise.
- Pedigrees will only show you if someone is affected (black symbol) or unaffected (white symbol).
If someone is a heterozygous carrier of a recessive disease, they will be depicted as unaffected.

PART 1 – MULTIPLE CHOICE – ANSWER ON YOUR SCANTRON CARD. 25 points total. Choose the SINGLE best answer to each question. If none of the answers seem correct, or if more than one seems correct, choose the one that seems **most correct**. Mark your Scantron card with a dark PENCIL. Each question is worth one point unless otherwise noted.

1. Why aren't many antibiotics effective against viruses? (which of the following statements is most correct regarding this question?)
 - A. In fact, most antibiotics are somewhat effective against viruses.
 - B. Viruses use conjugation to pump antibiotics out of their capsids.
 - C. Many antibiotics target bacterial ribosomes, and viruses do not have such a structure.
 - D. Viruses have acquired multiple antibiotic resistance genes.
 - E. More than one of the above statements (A-D) is correct.

2. The process of genetic alteration by pure DNA is _____
 - A. transduction
 - B. transmutation
 - C. transformation
 - D. conjugation
 - E. transposition

3. Which of the following statements is true?
 - A. Current U.S. policy on cloning is that reproductive cloning should be banned but therapeutic (or research) cloning should not be.
 - B. There is no verified claim of the reproductive cloning of a human being.
 - C. There is no verified claim of the reproductive cloning of any mammal.
 - D. Some attempts at human reproductive cloning have been made, but these individuals have died shortly after birth.
 - E. More than one of the above statements (A-D) is true.

4. Which of the following transgenic or genetically-modified organisms has not yet been created:
 - A. A tobacco plant that glows like a firefly
 - B. A soybean that is resistant to a potent herbicide (herbicide= plant killing chemical)
 - C. A big cow that produces more milk
 - D. A human cured of a genetic disease by germ line gene therapy.
 - E. All of the above have been created

5. A man with no family history of cancer-prone genetic diseases dies of a brain tumor. The tumor does not metastasize, but grows so large that it kills him. His wife wants to donate his liver to a friend in need of a transplant, and extract a sperm sample for in vitro fertilization. Which of the following statements is TRUE?:
 - A. His liver should not be used because it is probably full of cells containing multiple cancer-causing mutations
 - B. His sperm should not be used because they will give rise to cancer-prone kids
 - C. Neither his liver nor his sperm should be used, for all of the reasons given above
 - D. Both his liver and his sperm can be used; there will be no unusual risk of cancer

6. Debby the sheep is born with sheep phenylketonuria (PKU, an autosomal recessive disease). At age three, Debby the sheep is cloned. (The clone named Debby Jr.) At age six, Debby dies of colon cancer.
 - I. Does Debby Jr. have PKU (yes or probably not)?
 - II. Will Debby Jr. get colon cancer (yes or probably not)?
 - A. I = yes II = yes
 - B. I = yes II = probably not
 - C. I = probably not II = yes
 - D. I = probably not II = probably not

7. Fill in the blanks. A gene that encodes a protein required for the repair of certain types of DNA damage is likely to be a _____. A gene that encodes a protein required to relay a signal telling a non-dividing cell to divide is likely to be a _____.
- oncogene; tumor-suppressor gene
 - tumor-suppressor gene; oncogene
 - oncogene; oncogene
 - tumor-suppressor gene; tumor-suppressor gene
 - malignant, hemizygous
8. Which of the following statements is the most true about rare recessive alleles:
- They could be rapidly eliminated from the gene pool if modern medicine did not prolong the life of people affected by recessive genetic diseases
 - People who carry disadvantageous ones should probably not have children
 - First cousins are far more likely to share one than two unrelated people
 - On average, a new one is created every time a gamete is formed
 - C and D are both true
9. Which of the following (A-D) is TRUE of eugenics? If you think none are true, pick E.
- It is a pseudo-science that has been practiced in Nazi Germany, but not in the United States.
 - Although it may have been practiced in some U.S. states, it was never practiced in California.
 - It is currently in clinical trials at several major medical centers.
 - It has the potential rapidly eliminate low-fitness recessive alleles from the gene pool.
 - None of the above statements (A-D) are true.

10 & 11. The pedigree shows the inheritance of a genetic disease in three generations of a family

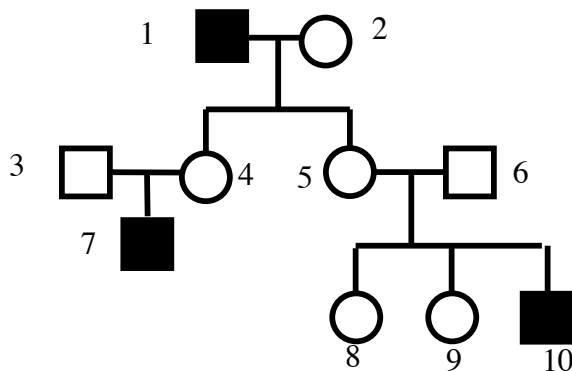

10. Based on the pedigree, the mode of inheritance of this disease could be
- Autosomal recessive
 - X-linked recessive
 - Autosomal dominant
 - X-linked dominant
 - A or B
11. Assume that the frequency of disease causing alleles in the general population, including those (#3 and #6) who married into the family, is very low. Given that assumption, then the mode of inheritance of this disease is most likely...
- Autosomal recessive
 - X-linked recessive
 - Autosomal dominant
 - X-linked dominant
 - Y-linked dominant

12 & 13. The pedigree shows the inheritance of a genetic disease in three generations of a family

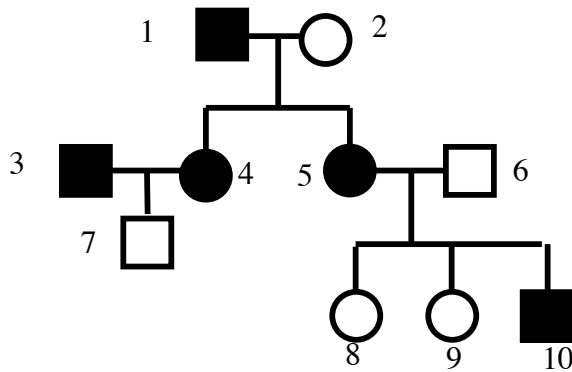

12. Based on the pedigree, the mode of inheritance of this disease could be

- A. Autosomal recessive
- B. X-linked recessive
- C. Autosomal dominant
- D. X-linked dominant
- E. C or D

13. Assume that many more generations of this family are followed, and it is observed that affected men never have affected sons, whereas, on average, about half of the sons born to affected women are also affected. Given that assumption, then the mode of inheritance of this disease is most likely...

- A. Autosomal recessive
- B. X-linked recessive
- C. Autosomal dominant
- D. X-linked dominant
- E. Y-linked dominant

14 & 15.

THIS PROBLEM IS WORTH 2 POINTS – FILL IN BOTH NUMBERS ON YOUR SCANTRON

A woman claims that either basketball stars Shaq O'Neil or Coby Bryant is the father of her child. DNA samples are taken from her (M), her kid (K), Shaq (S) and Coby (C), and typed for a polymorphic locus on chromosome 3. The figure shows the banding pattern obtained by the Southern blot procedure. Which statement is the most correct?

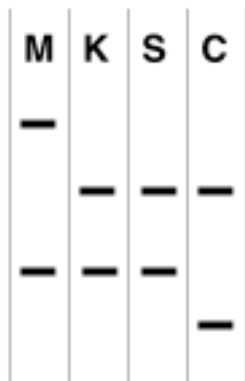

- A. Shaq may be the father, but Coby cannot be
- B. Shaq cannot be the father, but Coby may be
- C. Shaq cannot be the father, and Coby cannot be the father either
- D. Either man could be the father
- E. Shaq is more likely to be the father than Coby, based on the evidence.

16 & 17.

THIS PROBLEM IS WORTH 2 POINTS – FILL IN BOTH NUMBERS ON YOUR SCANTRON

An 8 kb plasmid is digested with EcoRI (E) and/or BamHI (B), and the digests are run on an agarose gel and stained. The results are shown below; molecular size standards are shown on the left.

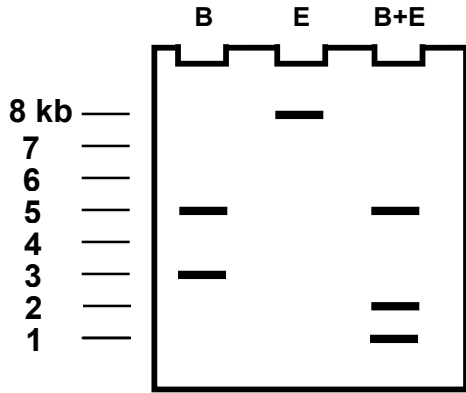

Based on the results of the gel, which plasmid map looks the most correct? Fill in answer E if you think none of them are correct. The light grey lines are to help you gauge distance.

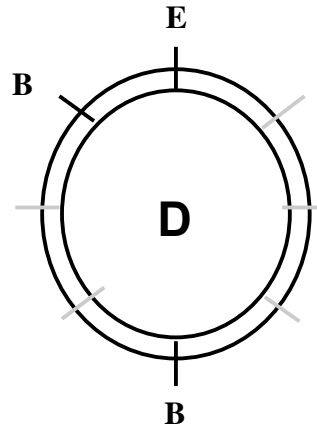
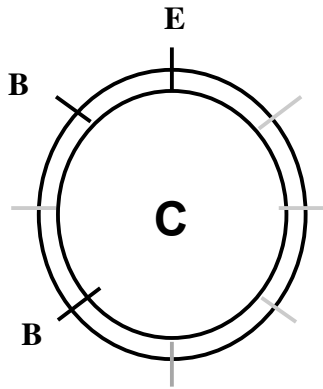
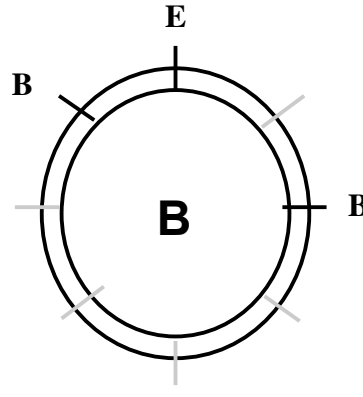
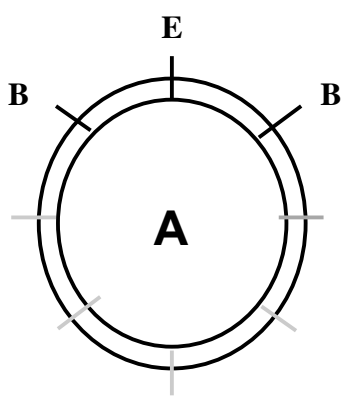

18. Sickle cell anemia is an autosomal recessive disease with an incidence of 1/400 among African-Americans. What is the approximate frequency of heterozygote carriers for this disease within this population? Assume Hardy-Weinberg conditions apply.
- A. 1/400
 - B. 1/200
 - C. 1/20
 - D. 1/10
 - E. 1/4
19. Your uncle (your mother's brother) has a rare genetic disease that is inherited in an autosomal recessive manner, but you, your parents and all your grandparents are unaffected. What is the approximate chance that you are a carrier (heterozygote) for this disease?
- A. 1/6, or 17%
 - B. 1/4, or 25%
 - C. 1/3, or 33%
 - D. 1/2, or 50%
 - E. 2/3, or 67%
20. The fraction of your alleles that you share with your uncle is...
- A. 1/16
 - B. 1/8
 - C. 1/4
 - D. 1/3
 - E. 1/2
21. For the population of an isolated southseas island, all the conditions of Hardy-Weinberg equilibrium are met except that inbreeding is rampant. Then the entire population is converted to a new religion that prohibits inbreeding, and the islanders begin to practice random mating. As a result of this change it can be predicted that...
- A. Allele frequencies will change but genotype frequencies will not
 - B. Genotype frequencies will change but allele frequencies will not
 - C. Neither allele frequencies nor genotype frequencies will change
 - D. Both allele frequencies and genotype frequencies will change
 - E. The incidence of rare recessive diseases will increase
22. Blood pressure is a multifactorial trait with a heritability of 0.6. A study is conducted on identical (monozygotic, or MZ) twins that were separated at birth and reared apart. They are compared to fraternal (dizygotic, or DZ) twins reared apart (NOTE: This often happens with twins given up for adoption). The most likely outcome of this study is that...
- A. MZ twins will have almost identical blood pressures, much more so than DZ twins
 - B. MZ twins will have more similar blood pressures than DZ twins, but there will still be significant variation between MZ twins due to environmental factors
 - C. Both MZ and DZ twins will have very similar blood pressures
 - D. DZ twins will have more similar blood pressures than MZ twins
 - E. Environmental factors are more important than genetic factors with regard to blood pressure
23. A trait due to a recessive X-linked allele in a large, randomly mating population affects one male in ten. What is the frequency of affected females?
- A. 1 in 10
 - B. 1 in 100
 - C. 1 in 1000
 - D. 1 in 10,000
 - E. 1 in 100,000
24. The first widely successful genetically modified crop was a strain of soybeans that...
- A. contained the human insulin gene.
 - B. contained a gene that made the elongated beanstalks round up for easier harvesting.
 - C. contained a gene from another plant that made them grow faster.

- D. contained a gene from a bacterium that made them resistant to a powerful herbicide.
- E. Did not carry a heritable germline genetic modification

25. Which of the following statements are true:
- A. All eggs produced by the same woman are genetically identical
 - B. All sperm produced by the same man are genetically identical
 - C. Both A and B
 - D. Neither A nor B

PART II - Short Answer Questions – Not Scantron – Write on Part II Answer Sheet

20 points total. Questions are worth 1 point each unless stated. Answers that are not clearly and carefully written will be marked wrong. Decimal answers must be written to two decimal places. Do NOT, for example, round 0.67 up to 0.7.

26-30. Below is shown the wild type coding strand of an open reading frame encoding a very short protein. Also shown are 4 mutant alleles of this gene.

Here is the relevant part of the genetic code:

ATG = Methionine (START) (Met in the three letter code)

TGA, TAA, TAG = STOP

AAT, AAC = Asparagine (Asn)

AAG, AAA = Lysine (Lys)

CCN (N = any base C, A, T or G) = Proline (Pro)

ATG AAA CCC ATG AAA TAA wild-type sequence

ATG AAA CCC AAG AAA TAA mutant allele I

ATG AAC CCA TGA AAT AA mutant allele II

ATG AAA CCC ATG AAG TAA mutant allele III

ATG TAA CCC ATG AAA TAA mutant allele IV

26. (2 points) What is the amino acid sequence of the wild-type protein? (Write your answer in this form: Met-Pro-Asn-Asn-Pro.)

For questions 26 through 30, use the following key:

- A. Silent substitution
- B. Missense substitution
- C. Nonsense substitution
- D. Frameshift
- E. Duplication
- F. Insertion
- G. Deletion

27. What type of change has occurred in mutant allele I (your answer should be a letter(s) from the key above - more than one answer may be correct)

28. Same question for mutant allele II

29. Same question for mutant allele III

30. Same question for mutant allele IV

31 & 32. The genes for eye color and wing shape are on the same autosomal chromosome in fruit flies. A test cross of a double heterozygote yielded the following numbers of progeny:

178 AB/ab	182 ab/ab
16 Ab/ab	24 aB/ab

31. In the double heterozygote parent, were the recessive alleles in cis or in trans? Or are the two genes unlinked? (Write “cis”, “trans” or “unlinked.”)

32. (2 points) What’s the distance between the two genes? (give the distance and include the appropriate unit of distance in your answer, or answer “unlinked”)

33 & 34. Three crosses were performed involving the linked genes Ang, But and Dmb. The Ang gene has alleles A & a, the But gene has alleles B & b, and the Dmb gene has alleles D & d. The genotypes obtained, and the frequency (in percent) at which they were obtained, is given below: :

AB/ab x ab/ab : 40% AB, 41% ab, 9% Ab, 10% aB

AD/ad x ad/ad : 44% AD, 44% ad, 6% Ad, 6% aD

BD/bd x bd/bd : 46% BD, 46% bd, 4% Bd, 4% bD

33. Which gene is in the middle? (2 points)

34. What’s the distance between Ang and Dmb?

35. (2 points) In a population of ten people, one is affected with cystic fibrosis and three others are carriers, while the other six are normal. What is the frequency of disease causing cystic fibrosis alleles in this population?

36-39. Fill in the blanks in the following statement, using words selected from the following five:

Allele
Gene
Genotype
Phenotype
Plasmid

The ___(#1)___ for arrogance has two ___(#2)___s, **A** and **a**. Individuals of the **aa** ___(#3)___ display the humble ___(#4)___, while those of the **AA** and **Aa** ___(#3)___s display the arrogant ___(#4)___.

36. Fill in blank #1

37. Fill in blank #2

38. Fill in blanks #3

39. Fill in blanks #4

40. (2 points) If you wanted to express a cloned human gene in the bacterium *E. coli*, so that you could grow up the bacteria in large batches and make the corresponding human protein, you would need to (you may choose none, or more than one):

- Remove the human introns
- Swap the human promoter/enhancer for a bacterial promoter
- Change the codons because otherwise the wrong amino acids would be specified
- Change the codons because bacteria use uracil instead of thymidine in DNA
- Insert the gene into a plasmid with a selectable marker and a bacterial origin of replication

HAPPY HOLIDAYS!